

OPTIMIZATION PROBLEM IN INVERTED PENDULUM SYSTEM WITH OBLIQUE TRACK

BAMBANG EDISUSANTO, TONI BAKHTIAR, ALI KUSNANTO

Abstract. This paper studies an optimization problem, i.e., the optimal tracking error control problem, on an inverted pendulum model with oblique track. We characterize the minimum tracking error in term of pendulum's parameters. Particularly, we derive the closed form expression for the pendulum length which gives minimum error. It is shown that the minimum error can always be accomplished as long as the ratio between the mass of the pendulum and that of the cart satisfies a certain constancy, regardless the type of material we use for the pendulum.

Keywords and Phrases: inverted pendulum, tracking error, optimal pendulum length.

1. INTRODUCTION

Direct pendulum as well as inverted pendulum models are important devices in supporting education and research activities in the field of control system as they have distinct characteristics such as nonlinear and unstable systems thus can be linearized around fixed points, its complexity can be modified, and they can easily be applied in actual systems. In the field of engineering, direct and inverted pendulums are utilized to monitor displacement of foundation of structures such as dam, bridge, and pier. Cranes work based on pendulum principles. In geology, inverted pendulum system aids us in detecting seismic noise due to macro-seismic, oceanic, and atmospheric activities [11]. In physiology we may employ the pendulum laws to study the human balancing [8, 9, 10]. The theoretical studies of pendulum systems are some. An analytical treatment of the stability problem in the context of delayed feedback control of the inverted pendulum can be found in [1], while a discussion on the limitations of controlling an inverted pendulum system in term of the Poisson integral formula and the complementary sensitivity integral is presented in [13]. Further, an \mathcal{H}_2 control performance limits

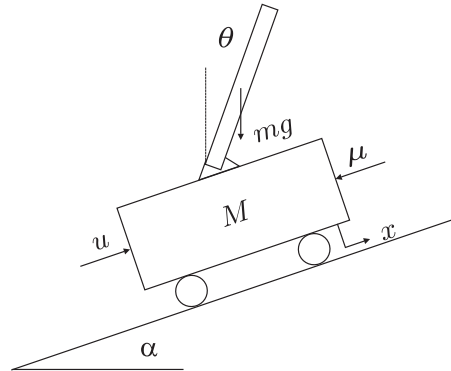

FIGURE 1. Inverted pendulum system with oblique track.

of single-input multiple-output system applied to a class of physical systems including cranes and inverted pendulums is provided by [6]. The performance limits of pendulum systems are characterized by unstable zeros/poles location. Recent theoretical study on factors limiting controlling of an inverted pendulum is carried-out in [7]. Calculation based on symbolic programming is performed to determine the admissible pendulum angle.

This paper examines an optimization problem on inverted pendulum systems with oblique track. We consider an optimal tracking error control problem, where our primary objective is to identify parameters which affect the stability of the pendulum system. Particularly, we aim to determine the optimal pendulum length which provides minimal tracking error. Our study is facilitated by the availability of analytical closed-form expression on optimal tracking error solution provided by previous researches [2, 3, 4, 5].

The rest of this paper is organized as follows. In Section 2, we consider the inverted pendulum system with oblique track including the equations of motion. Sections 3 briefly describes the tracking error control problem, in which the optimization problem is formulated. In Section 4 we apply the tracking error control problem into pendulum system and derive the optimal pendulum length which provides the lowest possible tracking error. We conclude in Section 5.

2. INVERTED PENDULUM SYSTEM

In this work we consider an inverted pendulum system as shown in Figure 1, where an inverted pendulum is mounted on a motor driven-cart. We assume that the pendulum moves only in the vertical plane, i.e., two dimensional control problem, on an oblique track of elevation α . We denote respectively by M , m , and 2ℓ , the mass of the cart, the mass of the pendulum, and the length of the pendulum. Friction between the track and the cart is denoted by μ and that between the cart and the pendulum by

η . We consider an uniform pendulum so that its inertia is given by $I = \frac{1}{3}m\ell^2$. Position and angle displacement of the pendulum are denoted by x and θ , respectively, and the force to the cart as the control variable by u . The coefficient of gravity is denoted by g .

Based on the law of energy conservation, the equations of motion of the pendulum can be written in the following nonlinear model:

$$\begin{aligned} (M + m)\ddot{x} + m\ell\ddot{\theta}\cos(\theta - \alpha) - m\ell\dot{\theta}^2\sin(\theta - \alpha) + \mu\dot{x} &= u - (M + m)g\sin\alpha, \\ \frac{4}{3}m\ell^2\ddot{\theta} + \eta\dot{\theta} + m\ell\ddot{x}\cos(\theta - \alpha) - mgl\sin(\theta - \alpha) &= 0. \end{aligned}$$

To linearize the model, we assume that there exists a small angle displacement of the pendulum, i.e., θ is small enough and thus $\sin\theta \approx \theta$, $\cos\theta \approx 1$, $\dot{\theta}^2 \approx 0$, and $\ddot{x}\theta \approx 0$. Additionally, we also assume that the cart starts in motionless from the origin as well as the pendulum, i.e., it is supposed that $x(0) = 0$, $\dot{x}(0) = 0$, $\theta(0) = 0$, and $\dot{\theta}(0) = 0$. The following linear model is then obtained:

$$\begin{aligned} (M + m)\ddot{x} + m\ell\ddot{\theta}\cos\alpha + \mu\dot{x} &= u - (M + m)g\sin\alpha, \\ \frac{4}{3}m\ell^2\ddot{\theta} + \eta\dot{\theta} + m\ell\ddot{x}\cos\alpha - mgl\theta\cos\alpha + mgl\sin\alpha &= 0. \end{aligned}$$

For simplicity in the further analysis, we shall assume that there are no frictions, i.e., $\mu = \eta = 0$. Thus, the application of Laplace transform enables us to convert the model from time domain into frequency domain as follows:

$$P_x(s) = \frac{\frac{4}{3}m\ell^2s^2 - mgl\cos\alpha}{[\frac{4}{3}(M + m)m\ell^2 - m^2\ell^2\cos^2\alpha]s^4 - [(M + m)mgl\cos\alpha]s^2}, \quad (1)$$

$$P_\theta(s) = \frac{-m\ell\cos\alpha}{[\frac{4}{3}(M + m)m\ell^2 - m^2\ell^2\cos^2\alpha]s^2 - (M + m)mgl\cos\alpha}. \quad (2)$$

Plants P_x in (1) and P_θ in (2) represent the transfer functions from force input u to the cart position x and the pendulum angle θ , respectively.

3. OPTIMAL TRACKING ERROR CONTROL PROBLEM

The considered inverted pendulum system can be represented in frequency domain as a simple feedback control system in Figure 2, where P is the plant to be controlled, K is the controller to be designed such that producing a certain control action, F is a sensor to measure the system output y which feeds-back to the system, r is the reference signal, d is the disturbance which exogenously enters the system, and e is the tracking error between reference input and sensor output, i.e., $e = r - Fy$.

A number $z \in \mathbb{C}$ is said to be *zero* of P if $P(z) = 0$ holds. In addition, if z is lying in \mathbb{C}^+ , i.e., right half plane, then z is said to be a *non-minimum phase zero*. P is said to be minimum phase if it has no non-minimum phase zero; otherwise, it is said to be non-minimum phase. A number $p \in \mathbb{C}$ is said to be a *pole* of P if $P(p)$ is unbounded. If p is lying in \mathbb{C}^+ , then p is an *unstable pole* of P . We say P is stable if it has no unstable pole; otherwise, unstable.

In classic paradigm, the central problem of a feedback system is to manipulate control input u or equivalently to design a controller K which stabilizes the system.

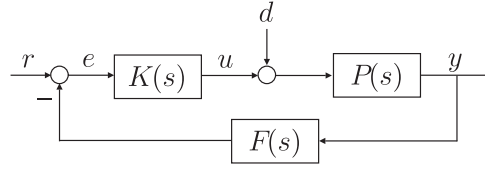

FIGURE 2. Feedback control system.

If the stability control problem is carried-out under the constraint of minimizing the tracking error then it refers to the optimal tracking error control problem. Formulating in time domain, the problem is to achieve minimal tracking error E^* , where

$$E^* := \inf_{K \in \mathcal{K}} \int_0^\infty |e(t)|^2 dt \quad (3)$$

with \mathcal{K} is a set of all stabilizing controllers. In modern paradigm, however, the primary interest is not on how to find the optimal controller, which commonly represented as Youla's parameterizations [12]. Rather, we are interesting in relating the optimal performance with some simple characteristics of the plant to be controlled. In other words, we provide the analytical closed-form expressions of the optimal performance in terms of dynamics and structure of the plant [3, 4, 5, 6]. From (1) and (2) we may construct a single-input and single-output (SISO) plant by selecting either $P = P_x$ or $P = P_\theta$, or alternatively a single-input and two-output (SITO) plant by selecting both plants, i.e., $P = (P_x, P_\theta)^T$.

Theorem 3.1. *Let P be an SISO plant which has non-minimum phase zeros z_i ($i = 1, \dots, n_z$) and unstable poles p_j ($k = 1, \dots, n_p$). Then the analytical closed-form expression of (3) is given by*

$$E^* = \sum_{i=1}^{n_z} \frac{2 \operatorname{Re} z_i}{|z_i|^2} + \sum_{k,\ell=1}^{n_p} \frac{4 \operatorname{Re} p_j \operatorname{Re} p_k (1 - \phi(\bar{p}_j))(1 - \phi(p_k))}{(\bar{p}_j + p_k) \bar{p}_j p_k \bar{\sigma}_j \sigma_k},$$

where

$$\phi(s) := \prod_{i=1}^{n_z} \frac{z_i + s}{\bar{z}_i - s},$$

$$\sigma_j := \begin{cases} 1 & ; n_p = 1 \\ \prod_{k \neq j} \frac{p_k - p_j}{\bar{p}_k + p_j} & ; n_p \geq 2. \end{cases}$$

Theorem 3.1 shows that the minimum tracking error is mainly determined by non-minimum phase zeros and unstable poles of the plant. In particular, it is clear that non-minimum phase zeros close to the imaginary axis contribute more detrimental effect. Moreover, unstable poles and unstable zeros close each other will deteriorate the minimum tracking error as revealed by following corollaries.

Corollary 3.1. *If P has only one non-minimum phase zero z and unstable pole p , both are real, then*

$$E^* = \frac{2}{z} + \frac{8p}{(z-p)^2}.$$

Corollary 3.2. *If P has only one non-minimum phase zero z and two unstable poles p_1 and p_2 , then*

$$E^* = \frac{2}{z} + \frac{8(p_1 + p_2)}{(p_1 - p_2)^2} \left[\frac{p_1(p_1 + p_2)}{(z - p_1)^2} - \frac{2p_1p_2}{(z - p_1)(z - p_2)} + \frac{p_2(p_1 + p_2)}{(z - p_2)^2} \right].$$

4. OPTIMAL PENDULUM LENGTH

We focus our analysis in controlling the cart position only. In other words we consider only an SISO plant P_x in (1). It is easy to verify that P_x has one non-minimum phase zero z and one unstable pole p as follows:

$$z = \sqrt{\frac{3g \cos \alpha}{4\ell}}, \quad (4)$$

$$p = \sqrt{\frac{3g(M+m) \cos \alpha}{\ell[4(M+m) - 3m \cos^2 \alpha]}}. \quad (5)$$

From the perspective of modern paradigm, the minimal tracking error of inverted pendulum system with oblique track can explicitly be expressed in term of pendulum parameters by substituting (4) and (5) into Corollary 3.1:

$$E^* = 4\sqrt{\frac{\ell}{3g \cos \alpha}} \left(\frac{\sqrt{M+m - \frac{3}{4}m \cos^2 \alpha} + \sqrt{M+m}}{\sqrt{M+m - \frac{3}{4}m \cos^2 \alpha} - \sqrt{M+m}} \right)^2, \quad (6)$$

By imposing a simple differential calculus on (6) we determine the length which provides the lowest possible tracking error

$$\ell^* = \frac{M(3 \cos^2 \alpha - 8 + \sqrt{1024 - 768 \cos^2 \alpha + 9 \cos^4 \alpha})}{(8 - 6 \cos^2 \alpha)\varphi}, \quad (7)$$

where φ is the "length density" constant which represents the ratio between mass and length of the pendulum, i.e., $\varphi := m/\ell$. We can see from (7) that the optimal length can be reduced by decreasing the mass of the cart or by selecting the material of the pendulum with bigger length density.

By reformulating (7) we may have

$$\frac{m}{M} = \frac{3 \cos^2 \alpha - 8 + \sqrt{1024 - 768 \cos^2 \alpha + 9 \cos^4 \alpha}}{8 - 6 \cos^2 \alpha}, \quad (8)$$

which suggests that, for a given elevation α , the minimum error can always be accomplished as long as the ratio between the mass of the pendulum and that of the cart

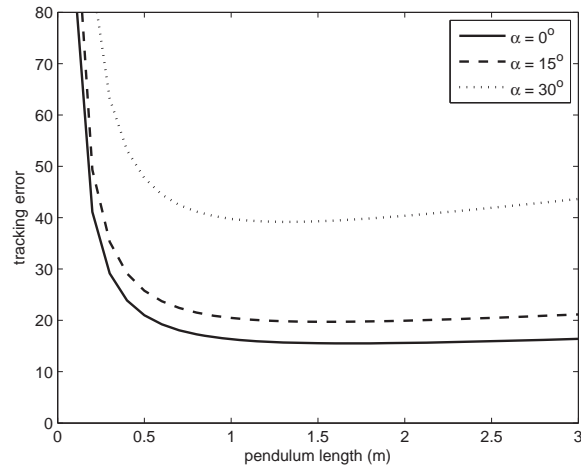

FIGURE 3. The minimum tracking error with respect to the pendulum length and the track elevation.

satisfies a certain constancy in the right-hand side of (8), regardless the type of material we use for the pendulum. In particular, for $\alpha = 0$ we have a kind of magic number

$$\frac{m}{M} = \frac{\sqrt{265} - 5}{2}.$$

To illustrate our result, we consider a rod-shaped pendulum made from platina mounted on a cart of weight 1 kg. We assume that the base of pendulum is fixed at radius of 1 cm and the length is varied. We may find that the pendulum has a length density of 3.3677 kg/m. Figure 3 depicts the minimum tracking error calculated in (6) with respect to the pendulum length ℓ and the track elevation α . It is endorsed that more elevation needs more control effort. Figure 4 plots the relation between the track elevation and the optimal pendulum length based on (7). It is shown that ℓ^* is a decreasing function of α , indicates that more elevation, and thus more control effort, can be compensated by selecting a shorter pendulum.

5. CONCLUSION

We have examined a simple but interesting optimization problem that arises in the field of control engineering. In the perspective of tracking error control problem of a pendulum, it has been shown that the lowest possible tracking error is solely dependent on the pendulum parameters. In particular, we provide the analytical closed-form expression of the optimal pendulum length. The approach adopted in this paper, however, enables us to design an apparatus that optimally accomplishes a certain objective.

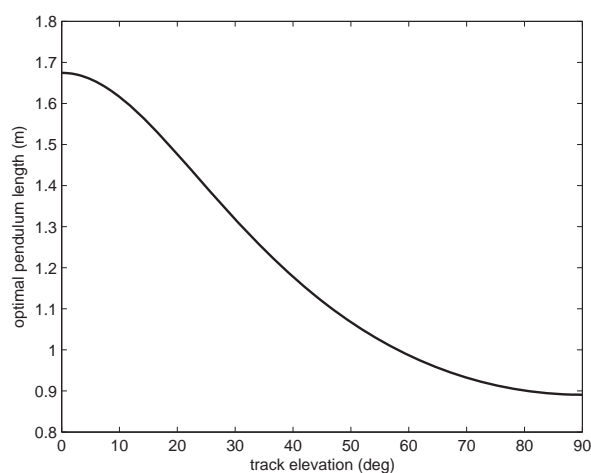

FIGURE 4. The optimal pendulum length with respect to the track elevation.

References

- [1] ATAY, F.M., "Balancing the Inverted Pendulum Using Position Feedback," *Applied Mathematics Letters*, **12**, 51–56, 1999.
- [2] CHEN, G., CHEN, J., AND MIDDLETON, R., "Best Tracking and Regulation Performance under Control Energy Constraint," *IEEE Transactions on Automatic Control*, **48**:8, 1320–1336, 2003.
- [3] CHEN, J., HARA, S., AND CHEN, G., "Optimal Tracking Performance for SIMO systems," *IEEE Transactions on Automatic Control*, **47**:10, 1770–1775, 2002.
- [4] CHEN, J., QIU, L., AND TOKER, O., "Limitations on Maximal Tracking Accuracy," *IEEE Transactions on Automatic Control*, **45**:22, 326–331, 2000.
- [5] HARA, S., BAKHTIAR, T., AND KANNO, M., "The Best Achievable H2 Tracking Performances for SIMO Feedback Control Systems," *Journal of Control Science and Engineering*, **2007**, 2007.
- [6] HARA, S. AND KOGURE, C., "Relationship between H2 Control Performance Limits and RHP Pole/Zero Locations," *Proceedings of the 2003 SICE Annual Conference*, Fukui, Japan, 1242–1246, 2003.
- [7] LAZAR, T. AND PASTOR, P., "Factors Limiting Controlling of an Inverted Pendulum," *Acta Polytechnica Hungarica*, **8**:4, 23–34, 2011.
- [8] LORAM, I.D. AND LAKIE, M., "Human Balancing of an Inverted Pendulum: Position Control by Small, Ballistic-Like, Throw and Catch Movements," *Journal of Physiology*, **540**:3, 1111–1124, 2002.
- [9] LORAM, I.D., GAWTHROP, P.J. AND LAKIE, M., "The Frequency of Human, Manual Adjustments in Balancing an Inverted Pendulum is Constrained by Intrinsic Physiological Factors," *Journal of Physiology*, **577**:1, 417–432, 2006.
- [10] LORAM, I.D., KELLY, S.M., AND LAKIE, M., "Human Balancing of an Inverted Pendulum: Is Sway Size Controlled by Ankle Impedance?" *Journal of Physiology*, **532**:3, 879–891, 2001.
- [11] TAURASI, I., *Inverted Pendulum Studies for Seismic Attenuation*, *SURF Final Report LIGO T060048-00-R*, California Institute of Technology, USA, 2005.
- [12] VIDYASAGAR, M., *Control System Synthesis: A Factorization Approach*, MIT Press, Cambridge, MA, 1985.

- [13] WOODYATT, A.R., MIDDLETON, R.H., AND FREUDENBERG, J.S., Fundamental Constraints for the Inverted Pendulum Problem, *Technical Report EE9716*, Department of Electrical and Computer Engineering, the University of Newcastle, Australia, 1997.

BAMBANG EDISUSANTO

Madrasah Tsanawiyah Negeri Pakem,
Jl. Cepet Purwobinangun (PKM), Sleman 55582, Yogyakarta.
e-mail: bambangedis@yahoo.com

TONI BAKHTIAR

Departemen Matematika, Institut Pertanian Bogor,
Jl. Meranti, Kampus IPB Darmaga, Bogor 16880.
e-mail: tonibakhtiar@yahoo.com

ALI KUSNANTO

Departemen Matematika, Institut Pertanian Bogor,
Jl. Meranti, Kampus IPB Darmaga, Bogor 16880.
e-mail: alikusnanto@yahoo.com