

Proceeding

International Seminar  
**CURRENT ISSUES AND  
CHALLENGES IN FOOD SAFETY:**  
science - based approach for food safety management



*editor:*

Ratih Dewanti-Hariyadi

Lilis Nuraida

Desty Gitapradiwi

Nelis Immaningsih

Purwiyatno Hariyadi



Southeast Asian Food and Agricultural Science and Technology (SEAFAST) Center  
Bogor Agricultural University

## **CHEMOREACTION DRYING AND ITS EFFECT ON BLACK PEPPER QUALITY**

**Nur Wulandari<sup>1,2</sup>, Soewarno T. Soekarto<sup>1</sup>, and Purwiyatno  
Hariyadi<sup>1,2</sup>**

<sup>1</sup> Department of Food Science and Technology, Faculty of Agricultural  
Engineering

<sup>2</sup> Southeast Asian Food and Agriculture Science & Technology  
(SEAFAST) Center, Bogor Agricultural University, Indonesia  
wulandari\_safardan@yahoo.com

### **ABSTRACT**

By using quicklime (Calcium oxide, CaO) as active reactant in chemoreaction drying, drying process of black pepper can be done at low temperature to minimize the loss of its volatile compounds and to maintain its quality. The objectives of this research were to study the drying capacity in chemoreaction drying of black pepper; and to analyze the effect of drying process to the volatile oil content of black pepper. The drying processes were conducted with 5 different weight ratios of CaO to fresh pepper i.e. 0.5, 1, 2, 5, and 20. The temperatures were relatively constant (approximately 29°C); but the higher the ratio of CaO to fresh pepper, the lower the RH of the drying process. Use of CaO: fresh pepper in the ratios of 2, 5 and 20 resulted in dried pepper with water content less than 12% (wet basis) in 4 - 5 days. This drying time was shorter than that obtained by sun drying that needs 8 days. Chemoreaction drying had no effect on the volatile oil content in black pepper produced compared to the fresh pepper. This drying processes resulted black pepper with volatile oil content between 2.44 - 2.70% (dry basis). The color of the oil was clear greenish yellow with good flavor quality.

*Keywords: black pepper, drying, quicklime, volatile oil*

### **INTRODUCTION**

Black pepper has been known as the largest and most important spice commodity in Indonesia. Black pepper processing is done simply by drying the fresh fruit pepper to targeted moisture content.

There are some problems related to black pepper quality exported from Indonesia to other countries, such as: microorganism contaminations, filthy, poor moisture content, and loss of volatile oil compounds. Those problems caused by improper or inadequate drying process. Sun drying process can't achieve adequate moisture content therefore cause moldy black pepper. However, mechanical drying that conducted in high temperature may cause loss of volatile compounds. In addition, mechanical drying equipment is expensive with high energy supply requirement. To achieve the finest quality, black pepper should be dried in a fast, low temperature drying process. One alternative can be used to process in such drying condition is by using materials with high reactivity to humidity of drying chamber, that can also lowered the moisture content of the raw material.

Quicklime (CaO) is a potential material that easily reacted with water in drying air (humidity). It's very reactive to water and can produce  $\text{Ca(OH)}_2$  as product reaction. It can generate low relative humidity (RH) of dry air and has a relatively cheap price (Harjadi, 1990). It has strong water reactant capacity and can release some heat during its exothermic reaction with water. The released heat during the reaction is not so intense, so that the temperature of chemoreaction process is still low. The drying process by using the reactivity of CaO to water is named chemoreaction drying process.

Some researches of chemoreaction drying have been conducted to fish fillet, paddy, nutmeg, tomato seeds and hot pepper seeds. Those experiments occurred in relatively high drying rates, and resulted in some better quality products. Potencies of chemoreaction drying should be strengthened by basic data of its drying process to produce high quality and reproducible products. The objectives of this research were to study the drying capacity in chemoreaction drying of black pepper; and to analyze the effect of drying process to the volatile oil content of black pepper.

## MATERIALS AND METHODS

### Materials

The main materials were quicklime, fresh pepper fruits, and chemoreaction drying equipment that was equipped by analytical balance (Figure 1). Chemoreaction drying equipment had an internal space of 50 cm x 50 cm x 60 cm with wood and styrofoam door and fiberglass door. Chemical analyses used Bidwell Sterling equipment, Atomic Absorption Spectrophotometer (AAS), desiccators, and some glassware.

Quicklime was collected from quicklime furnace owned by PD Djaja Ciampea Bogor. Variety of pepper fruit was Lampung Daun Lebar (LDL), which collected from Cibadak Sukabumi. Prior to the drying processes, the moisture content of fresh pepper fruit and the volatile oil content were measured (AOAC, 1995). Weight changes of pepper were evaluated by weighing from outside of the equipment, without opening the doors.

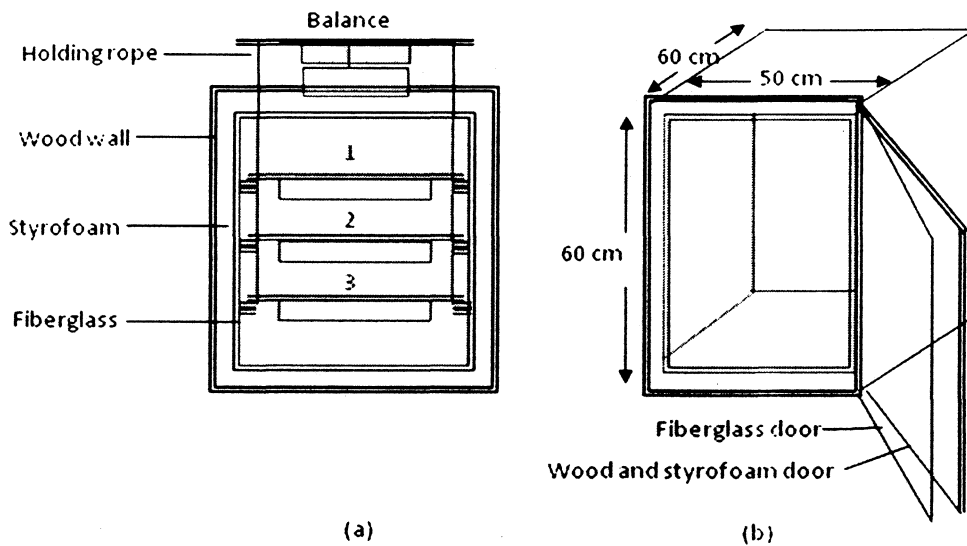

**Figure 1.** Construction of chemoreaction drying equipment (a) front side, and (b) drying chamber with two doors

## Methods

Quality requirements for black pepper were regulated in National Standards of Indonesia (Standar Nasional Indonesia, SNI 01-0005-1995). The maximum moisture content for black pepper is 12% wet basis (w.b.). This experiment used several ratios of CaO to fresh pepper (R) to know their capacity on reaching the moisture content standard. From this experiment, we can get the optimum ratios on chemoreaction drying process. The drying time and the drying rate profile during chemoreaction drying can also be observed.

The amount of quicklime stated as weight of CaO (CaO content was analyzed by AAS). For each ratio, fresh pepper was made at similar weight (230 g) as it can fulfill the tray in one layer of pepper. Experiments were conducted with some ratios that were less or more than the need of chemoreaction drying process, i.e R 0.5, 1, 2, 5, and 20. The drying processes were evaluated from the decrement of fresh pepper weight (and also fresh pepper moisture content). Moisture content of dried black pepper were analyzed by oven drying method and calibrated by loss of volatile oil compound in black pepper. Volatile oil content were determined by AOAC (1995) as volume (ml) per 100 g sample.

## RESULTS AND DISCUSSION

### Profile of Chemoreaction Drying Process

Figure 2 showed the profile of drying processes of black pepper using 5 different ratios of CaO to fresh pepper (R). Initial moisture content of the fresh pepper were 176.3 - 178.5% dry basis (d.b.) that equal to 63.8 - 64.1% w.b.

Initially, the moisture contents were highly decreased, and by the time of drying, decrement of moisture contents were getting slower and finally achieved certain moisture contents. The higher the ratios, the faster the moisture content's decrement, as it showed by the high slopes of the drying curves. The use of CaO to fresh pepper at ratios of 0.5 and 1 did not produce the expected moisture content of dried pepper (12% w.b.). While ratios of 2, 5 and 20 resulted in dried pepper with moisture content less than 12% w.b.

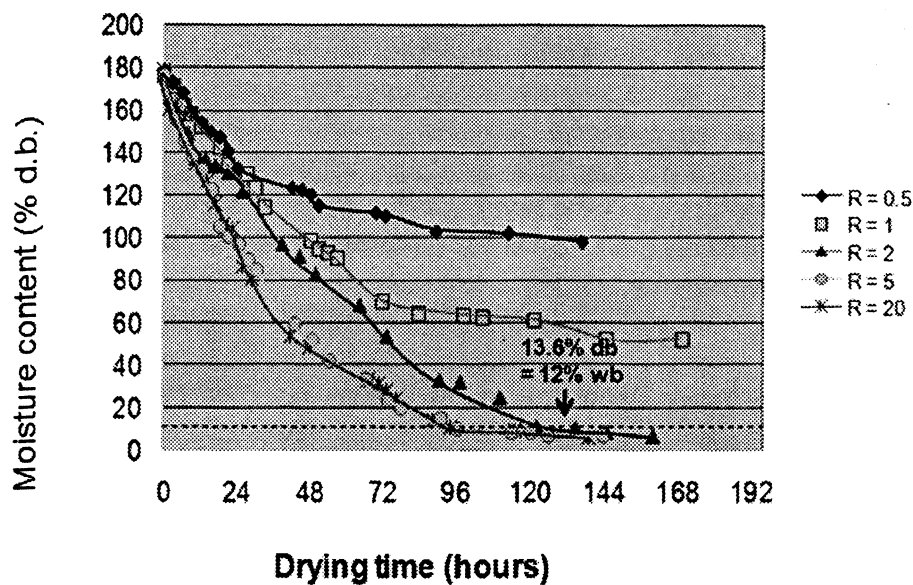

**Figure 2.** Profile of black pepper's moisture content (% d.b.) during chemoreaction drying at various R

### Drying Time

Drying times were determined by making a horizontal line at moisture content level of 12% w.b. (similar to the moisture content level of 13.6% d.b.). The data can be seen in Table 1. Ratios of 2, 5 and 20 resulted in dried pepper with moisture content less than 12% w.b. in 5, 4, and 4 days respectively. These drying times were shorter than that of conventional sun drying which needs 8 days for drying process (Halim, 1995). Therefore chemoreaction drying can be used as a substitute for sun drying method or used as a complement for continuing sun drying process that can't achieve the moisture content standard.

**Table 1.** Drying time of black pepper by chemoreaction drying method at various R, compare to sun drying method

Drying methods		Drying time to 12 % w.b.	
		Hours	Days
Chemoreaction drying	R 0.5	nd	nd
	R 1	nd	nd
	R 2	119.5	5
	R 5	92.3	3.9
	R 20	89	3.7
Sun drying		192	8

The use of R 0.5 and R 1 did not achieve the expected moisture content. The pepper was decayed and moldy and also generated some unpleasant odor, caused by high moisture content level. While R 2, R 5, and R 20 resulted in dried pepper with moisture content less than 12% w.b., and had greenish brown color, wrinkled surface, and generated specific odor of black pepper. From this results, the optimum ratios for drying process was 2, as this ratio can achieve moisture content level less than 12 % w.b., but the result was not different from R 5 and R 20, although there was a tendency that the higher the ratios, the lower the final moisture content were, and the shorter the drying time .

**Effect of Chemoreaction Drying to Volatile Oil Content**

Chemoraction drying had no effect to the volatile oil content of black pepper produced compared to the fresh pepper (Table 2). These drying processes resulted black pepper with volatile oil content between 2.44 - 2.70% (dry basis). Ratios of R 2, R 5 and R 20 had no effect to the loss of volatile oil content of dried black pepper. The volatile oil loss were between 1.74% - 4.87% and the oil appearance was clear greenish yellow with good flavor quality. Ratios of R 0.5 dan R 1 had great loss in volatile oil content due to inadequate drying process resulted in decayed fresh pepper. The

volatile oil loss for R 0.5 and R1 were 28.28% and 20.80% respectively. The oil appearance is dark brown, with poor flavor

**Table 2.** The loss of volatile oil content in black pepper resulted from chemoreaction drying, in various ratio of CaO to fresh pepper

Ratio of CaO: fresh pepper	Volatile oil content in fresh pepper		Volatile oil content in dried blackpepper		Loss of volatile oil (% d.b.)	Black pepper produced
	ml/100 g d.b.	% d.b.	ml/100 g d.b.	% d.b.		
R = 0.5	2.76	2.44	1.98	1.75	28.28	Decayed
R = 1	2.88	2.54	2.28	2.02	20.80	Decayed
R = 2	3.04	2.69	2.98	2.64	1.74	Dried
R = 5	2.76	2.44	2.66	2.35	3.74	Dried
R = 20	3.06	2.70	2.91	2.57	4.87	Dried
Oven drying*	-	-	-	-	17.80	Dried
Sun drying*	-	-	-	-	10.65	Dried

\*Halim, 1995

Major volatile oil compounds in black pepper are hydrocarbon monoterpen and some hydrocarbon sesquiterpen (Purseglove *et al.*, 1981). By using oven drier with temperature 80°C, loss of volatile oil content in black pepper is high, approximately 17.80% compared to the volatile oil of fresh pepper (Halim, 1995). High loss in volatile oil content usually caused by high temperture exposure during drying. Sun drying method also decreased the volatile oil content in black pepper approximately 10.65% (Halim, 1995). Purseglove *et al.* (1981) explained that the loss in volatile oil and piperin content is relatively low during sun drying process. According to Guenther (1990), terpen and unsaturated sesquiterpen easily oxidized under sunlight and oxygen, and caused off flavor in black pepper.

## CONCLUSIONS

The use of CaO to fresh pepper ratios 2, 5, and 20 can achieve expected moisture content (12% db) in 4 – 5 days; while in R 0.5 and 1, the pepper was moldy and decayed due to higher moisture content.



The higher the ratios of CaO to fresh pepper, the shorter the drying time needed. Chemoreaction drying can be used to substitute or to continue the sun drying process.

Chemoreaction drying had no effect on the volatile oil content of black pepper produced compared to the fresh pepper. This drying processes resulted black pepper with volatile oil content between 2.44 - 2.70% (dry basis). The color of the oil was clear greenish yellow with good flavor quality.

### **Aknowledgements**

We would like to say thank to URGE Batch V Project for supporting this research, and to SEAFAST Center IPB for the opportunity to present this paper.

### **References**

- [AOAC] Association of Official Analytical Chemists. 1995. Official Methods of Analysis of the Association of Official Analytical Chemists, 14<sup>th</sup> ed. AOAC, Inc. Arlington, Virginia.
- Guenther E. 1990. Minyak Atsiri. Jilid I. Terjemahan oleh Ketaren S. Penerbit Universitas Indonesia (UI Press), Jakarta.
- Halim B. 1995. Pengeringan biji lada (*Piper nigrum* Linn) secara absorpsi dengan kapur api (CaO). Skripsi. Jurusan Teknologi Pangan dan Gizi, Fateta, IPB, Bogor.
- Harjadi W. 1990. Ilmu Kimia Analitik Dasar. PT Gramedia, Jakarta.
- Purseglove JW, Brown EG, Green CL, Robin SRJ. 1981. Spices. Volume I. Longman, London.
- Standar Nasional Indonesia. 1995. Standar Mutu Lada Hitam SNI 01 - 0005 - 1995, Jakarta: BSN