

# INVESTMENT STRATEGY FOR THE DEVELOPMENT OF FISHERIES SECTOR IN INDONESIA : AN APPLICATION A DYNAMICS REGIONAL ECONOMICS ALLOCATION MODEL (DREAM)

Tridoyo Kusumastanto<sup>1</sup>

## ABSTRACT

The purpose of this research is to develop a national investment policy planning model for the Indonesian fisheries sector. The specific objective is to establish a development strategy for the fisheries sector, with specific attention results from the proposed study will be useful in providing policy directions and indicating magnitude of the investment required for efficient planning of the sector.

## INTRODUCTION

Objectives of fisheries development are usually in conflict with one another. Therefore, it is important to set fisheries development policies which will achieve appropriate balance between growth and sustainability. Because investment plays a key role in economic growth, it is important to determine the investment strategies which will balance economic growth and sustainable development. Development policies frequently have multi-objectives and are dynamic. A dynamic process in which investment decisions are taken at one point in time have a dominant, but delayed impact on the economic trajectory of development.

Decision making in fisheries development in Indonesia is taken as multi-level system (cabinet ministries, regional, and project levels). Economics activities, resource availability, and population are varied among regions of Indonesia. Figure 1 in appendix illustrates the region of Indonesia. Given these conditions, it is necessary to perform a detailed analysis of investment strategies and since the Dynamic Regional Economic Model (DREAM) will be used in this study, it is possible to a multi-level, and multi-stage development strategies.

1. Staf Pengajar Jurusan Sosial Ekonomi Perikanan, Fakultas Perikanan IPB

## DEFINING THE PROBLEM

The sharp drop in petroleum prices since early, 1980's, has forced the Government of Indonesia (GOI) to diversify the economic. This revenue decline from oil, has encouraged the expansion of export products from fisheries sector. The GOI targeted increase in GDP from fisheries sector by 14,9% per year in the next five years (DGF,1990). The fisheries sector has thus become more export oriented. Limited funding of investment from government, has encouraged the greater reliance on private sector to increase its role in fisheries development. Therefore, foreign exchange earning and profit oriented commodities are now given greater emphasis in the fisheries development plan.

In addition to limited government budget, the objectives of fisheries development in Indonesia, are in conflict with one another. The decision makers have to decide between such goals as maximizing social benefits and promoting economic efficiency. At this moment, fisheries development in Indonesia is facing a crossroad, where investment must be made. These problems must be addressed. Which is the best strategy to obtain the above mentioned objectives? Which objective should be given the highest priority? Is it to improve standard of living by fostering economic growth and export, or distribution of income through increased employment? Is investment in labor intensive projects designed to increase export more efficient in attaining a full employment objective than capital intensive investment? Will the substitution of public investment by private setor funds in the fisheries result in over-exploitation and mismanagement of the resource? Does decentralization policy enhance economic growth, considering the diversity of regional resource availability, market, and population? These choices have brought forward different sets of problems and developmental dilemma.

## OBJECTIVE OF THE RESEARCH

The main purpose of this study is to evaluate the investment strategy for the development of the fisheries sector. Considering the above conditions, the study tries :

- (1) to review critically the Fifth GOI's Fisheries Five-Year Development Plan by examining the relationships among goals, resource constraints, and environmental sustainability at the cabinet, ministerial, regional and project levels. The model will be built using the information given in the Fifth GOI's Fisheries Five Year Development Plan. This model will be used to evaluate the proposed plan. The relationships among the objectives stated in the plan will be critically reviewed. This model will be used to determine the strong and weak points of the present planning process as it relates to the exploitation and management of fisheries resource;

- (2) to evaluate investment strategies which will help in the attainment of the fisheries development goals of Indonesia. The capital budgeting techniques will be used to evaluate the investment choices made at the project level. Linear Programming (LP) and Lexicographic Goal Programming (LGP) model will be used at the project level to determine optimum resource allocation. The results will be incorporated into the DREAM model using the HALP procedure to determine how the optimum solution at the project level alters, regional, ministerial, and planned goal achievements at the cabinet level;
- (3) to determine an optimal rate of growth which will enhance sustainability in fisheries development. The DREAM model and the HALP procedure will be used to determine the levels of changes at each stage which will allow decision makers to attain the objectives while satisfying the desired growth rate, and the level of environmental, social, and resource sustainability proposed by government;
- (4) to recommend a development strategy for the fisheries sector with attention to investment policies with considerations for sustainable development. The results obtained from the model, and reviewed development plan will be used to develop an investment strategy which will satisfy most of the desired objectives at each level. A set of a recommendations, which allows growth and sustainability, will be proposed, based on the results obtained, and government planned objectives for Indonesia.

## MODEL

Given the problems above, it is necessary to perform a detailed analysis of investment strategies under the condition of multi-objective, multi-level policy decisions in one sector which contributes relatively a small part of the whole Indonesian economy. Therefore, a one-sector model is considered suitable. In order to solve the problems of regional diversity, multiple-objective, multi-stage, and multi-level decision making, a Dynamic Regional Economic Model (DREAM) will be developed. The first step in formulating socially sustainable fisheries development policy is to recognize resource limitations and to realize that hard choices must be made (Bailey, 1988). The results of marine fisheries combined with inland/fresh water fisheries estimation will be used as total fisheries resource to be allocated for fisheries development.

Decision making in fisheries sector development in Indonesia exhibits a hierarchical structure. At the top level, the cabinet is the decision maker of aggregate economic policies. At the ministerial level, Ministry of Agricultural with Directorate General of Fisheries (DGF) as decision maker, is concerned with national fisheries policies. Other ministries which are related to fisheries policies, are Ministry of Industry and Ministry of Environment. The cabinet macro-economic policies impose certain constraints on feasible development option at ministerial levels. Similarly, decisions

taken at both the cabinet and ministerial levels impose further constraints on the regional, large scale business firms, small scale business firms, and individual small scale enterprise decision makers, at project level. Because each component may have more than one goal, an additional dimension of complexity in the policy framework is introduced. Nevertheless, it should be stressed that the policies implemented at higher levels can be coordinated, but can not completely control the goal seeking activities at lower levels (Mesarovic, Macko and Takehara, 1970 in Batten, 1984).

Planners and policy makers at both the national and regional levels must consider a range of policy objectives (implying a multidimensional welfare function) and a multiplicity of criteria (for example: efficiency, equity, ecological balance, etc.) to reflect the diverse goals and aspirations which exist amongst the community. Their collective decision making must ultimately lead to an allocation of resources (commodities, investment, etc.) which reflects a meaningful compromise between the various policy options (Batten, 1984).

Batten (1984) stated that multi-objective programming and multi-criteria evaluation models have two important methodological aspects which have been largely overlooked in the majority of multi-dimensional models developed in the seventies. Firstly, the typology just described is by no means unambiguous. A second deficiency inherent in the current suite of multi-dimensional models is that the scant consideration given to the time dimension. Planning is clearly a dynamic process, in which investment decisions made at one point in time have a dominant, but usually delayed, impact on the macro-economic trajectory development. It is suggested that adaptive learning procedures are an appropriate tool for the evaluation of multistage compromise solutions.

The complex interaction between decision levels (cabinet, ministerial, regional, and project levels) in the fisheries sector and multiple objectives in the various components at each level, can only be analyzed in an appropriate way if the guiding aspirations and interests of each actor are understood. The multidimensional nature of this problem implies at least three conflicting categories, namely :

- (1) Conflicts between various priorities, goals or targets within one component of the system (for example, frictions between increase export earning and domestic consumption criteria at the Ministry of Agriculture);
- (2) Conflicts between various priorities, goals or targets set by different components at one level of the system (for example, friction between business firms which strive to maximize profit and individual labor which strive to maximize their income);
- (3) Conflicts between various priorities, goals or targets set by different components at different levels of the system (for example, friction between business firms which strive to maximize profit and Ministry of Environment which strive to minimize damage to environment).

An appropriate compromise framework has to be devised which leads to satisfactory results for both the components and the objectives at various levels of the fisheries system. The composite multidimensional methodology which we shall now describe is of the interactive type, and referred to as Harmonious Adaptive Learning Procedure (HALP) which is an interactive process of a set of adaptive learning procedure. The adaptive learning procedure implies the notion of satisficing rather than optimizing.

Consider a multi-level system, in which there are R components ( $r = 1, 2, \dots, R$ ). Each component has a set of J objectives ( $J = 1, 2, \dots, J$ ):

$$w_r = (w_{1r}, \dots, w_{jr}) \dots \dots \dots (1)$$

which it wishes to be maximized and which depend on I decision variables ( $i = 1, 2, \dots, I$ ):

$$x_r = (x_{1r}, \dots, x_{ir}) \dots \dots \dots (2)$$

If it is assumed that each component can solve its internal goal conflicts, it can be taken for granted the existence of a component welfare function :

$$w_r = \sum_j \tau_{jr} w_{jr} \dots \dots \dots (3)$$

where  $\tau_{jr}$  is the weight attached to objective j by component r.

In such a system a set of side-conditions which are called relational constraints delimit the action space of each decision maker (for example, technical, economic, environmental and institutional constraints). These relational constraints are of two types, namely :

(a) internal constraints:  $A_r X_r \leq a_r \dots \dots \dots (4)$

(b) joint constraints :  $\sum_r B_r X_r \leq b$ .

where :

(a) internal constraints are constraints within components and there is no coordination by cabinet or higher decision maker needed; (b) joint constraints are constraints when coordination by the central or higher level decision maker is needed.

In this study, it is assumed that the cabinet's or higher level decision maker's objectives are the sum of the subsystem objective ( $\sum_r w_r$ ). This assumption shall be relaxed completely. Furthermore, it shall be allowed each subsystem's set of objectives to differ from the next. However, it is assumed that each subsystem/component contain decision makers who can perform the following functions or steps:

(1) Rank their set of objectives in order of importance on an ordinal scale, such as 'most important', 'next most important', and so on. This prioritization of goals

corresponds to a lexicographic ordering of each set, which closely resembles the decision making technique adopted by many policy makers.

- (2) Relate each objective to a (minimally) acceptable achievement level so that each goal can be expressed in the form of an achievement constraint, namely

$$C_r X_r \geq w_r \dots\dots\dots (5)$$

where :

$C_r$  is a (J by I) matrix of impact coefficients which are specified a priori in such a fashion that all  $x_{ijr}$  are non-negative.

The analyst in subsystems r must be prepared to calculate various ideal solutions by successively maximizing each of the J objectives  $w_r = (w_{1r}, \dots, w_{jr})$  separately, subject to various sets of (normalized) restrictions, denoting the maxima by  $w_r^* = (w_{1r}^*, \dots, w_{jr}^*)$  and corresponding (normalized) combinations of the decision variables by  $x_{jr}^* = (x_{1jr}^*, \dots, x_{ijr}^*)$

At any stage, it is not necessary to accept a value of  $w_{jr}$  (min) which is lower than the following:

$$w_{jr} (\text{min}) = \text{Min} \{w_{jr} (x_{kr}^*)\} \dots\dots\dots (6)$$

and this 'pessimistic' value may be compared with the corresponding target value. The initial set of R ideal solutions will be termed independent because they are computed in the absence of any coordination by the higher level planning unit through the distribution of common resources ( $b_1, \dots, b_R$ ).

The following distance metric can be used to evaluate the minimum discrepancy between any compromise solution and the ideal solution :

$$\text{Minimize } I_r = \sum_{j=1}^J \sum_{i=1}^I X_{ijr} \log (x_{ijr}/X_{ijr}^*) \dots\dots\dots (7)$$

It should be understood that this discrepancy or penalty function (7) is not a welfare or utility function, but is actually a measure of information gain. It is equivalent (at its first approximation) to the minimization of the Chi-square statistic :

$$\sum_{j=1}^J \sum_{i=1}^I (X_{ijr} - X_{ijr}^*)^2 / X_{ijr} \dots\dots\dots (8)$$

and is therefore a suitable measure of deviation or goodness of fit. The arbitrary choice of this function for generating trial compromise solution is no drawback in an interactive procedure where the decision makers have the opportunity to adapt to each solution and reformulate their desires in a stepwise manner. Moreover, operational and efficient algorithm for the solution of this discrepancy function subject to linear constraint

systems are readily available. The above mentioned gives rise to the following independent compromise model for each subsystem  $r$  :

$$\begin{aligned} & \text{Minimize } I_r \text{ subject to} \\ & \text{(a) internal constraints : } A_r x_r \leq a_r \text{ ..... (9)} \\ & \text{(b) achievement constraints : } C_r x_r \geq w_r \text{ (min)} \\ & \text{(in order of priority) } x_r \geq 0. \end{aligned}$$

The solution of the problem is approached in a series of interactive steps which is an adaptive learning procedure. Each trial compromise solution may be judged by the decision maker in terms of its feasibility and desirability, and modification can then be made.

Since each subsystem  $r$  has resolved its internal goal conflicts by means of adaptive learning procedure, it now possesses a yardstick by which to measure further compromises. The internal constraints embodied in each subsystem's independent compromises model are now relayed to the higher level decision makers, together with the resulting values of  $x_r$  so determined. The higher level decision maker's problem may now be formulated as follows :

$$\begin{aligned} & \text{Minimized } I \text{ subject to} \\ & \text{(a) subsystem constraints : } A_1 x_1 \dots \leq a_1 \dots \dots \dots (10) \\ & \text{(b) joint constraints : } B_1 x_1 + \dots B_R x_R \leq b \\ & \text{(c) achievement constraints : } C_1 x_1 + \dots C_R x_R \geq w \text{ (min)} \end{aligned}$$

where  $I$  is a smaller distance metric than the one used for each subsystem, namely  $I_r$ , as given in (7), but is summed over all  $R$  subsystems.

The initial values of  $x_r$  provided by the subsystems allow the higher level decision maker to calculate a set of resource distribution coefficients ( $B_1, \dots, B_R$ ) which satisfy  $\sum B_r x_r = b$ .

Given this information, the distribution of common resources by means of a similar adaptive learning procedure can be utilized by the subsystems. In this case, the relational constraints included the (internal) subsystem constraints and the (joint) coordinating constraints. The set of achievement constraints are based on the objectives of the level of the decision maker himself, although some relaxation of these targets may be needed to find a feasible compromise solution.

Once this solution has been determined, the cabinet generates a provisional distribution of resources ( $b_1, \dots, b_R$ ) to each subsystems. This gives rise the following coordinated compromise model for each subsystem  $r$  :

Minimize  $I$ , subject to

- (a) internal constraints :  $A_r x_r \leq a_r$
- (b) joint constraints :  $B_r x_r \leq b_r$
- (c) achievement constraints :  $C_r x_r \geq w_r$

Once again, the subsystems solve their revised problems by means of an adaptive learning procedure, and report the results back to the cabinet. In the direct method of multilevel programming, each subsystem reports the shadow prices  $\pi_r$  of the common resources back to the cabinet. Given this information, the cabinet revises the distribution of resources and may also suggest that certain achievement levels set by the subsystems be relaxed. Once an efficient distribution of common resources ( $b_1, \dots, b_r$ ), which enables the cabinet and each subsystem to reach a satisfactory compromise solution is found, the coordination process is complete.

In reality, planning is a dynamic process in which investment decisions taken at one point in time have a major, but delayed, impact on the macro-economic trajectory of development. Therefore, investment decision making should be analyzed by multistage process in which goal conflicts may be resolved simultaneously or sequentially through time. The introduction of the time element into multidimensional decision making may complicate the earlier formulation, but it nevertheless allows more realistic trajectories of learning and compromise to be developed. By restating the compromise models (7), (10) and (11) in a dynamic form for the cabinet planning is as follows:

$$\text{Minimize } I = \sum_{r=1}^R \sum_{j=1}^J \sum_{i=1}^I X_{ijr}(t) \log \{X_{ijr}(t)/X_{ijr}^*(t)\} \dots\dots\dots (12)$$

subject to the following constraints for each stage or time period t:

$$A_1(t) X_1(t) \leq a_1(t) \dots\dots\dots (13)$$

$$\begin{aligned} A_R(t) X_R(t) &\leq a_R(t) \\ B_1(t) X_1(t) + \dots\dots\dots B_R(t) X_R(t) &\geq b(t) \\ C_1(t) X_1(t) + \dots\dots\dots C_R(t) X_R(t) &\leq w(t) \end{aligned}$$

As before, it is assumed that the initial values of the state and decision variables, namely  $X_r(0)$ , are provided by the r subsystems, which first calculate compromise solutions which resolve their internal goal conflicts by adaptive learning in the absence of any coordination from the cabinet. stage 1 begins with the calculation of a set of resource distribution coefficients ( $B_1(1), \dots, B_r(1)$ ) which satisfy the following resource constraint for the first period, namely:

$$\sum B_r(1) X_r(0) < b(1) \dots\dots\dots (14)$$



Given this information, the cabinet must now search for an efficient compromise solution for the distribution of these common resources during the first period ( $t=1$ ). The relation constraints include the internal (A) constraints and the coordinating (B) constraints. The set of achievement (C) constraints are largely based on the cabinet's objectives.

Once this solution has been found, the cabinet generates a distribution of resources ( $b_1(1), \dots, b_R(1)$ ) for each subsystem  $r$  (in which  $t=1$  at this stage):

$$\text{Minimize } I_r = \sum_{j=1}^n \sum_{i=1}^m X_{ijr} \log \{X_{ijr}(t)/X_{ijr}^*(t)\} \dots \dots \dots (15)$$

subject to the following constraints:

$$A_r(t) X_r(t) \leq a_r(t); B_r(t) X_r(t) \leq b_r(t); C_r(t) X_r(t) \geq W_r(t)$$

The subsystems can solve this revised problem by means of an adaptive learning procedure, report the result back to the cabinet, and then receive a new distribution of resources for the second stage ( $t=2$ ). The resulting series of iterations between the higher level decision maker and each subsystem are repeated until all  $T$  stages (time periods) have been completed. The schematic representation of multistage process which allows for compromise solutions by adaptive learning at each stage, together with further compromises between stages and overall control by the higher decision makers, is shown in Appendix 2.

The Dynamic regional Economic Allocation Model (DREAM) is a multi-regional model above which has been reorganized as a multi-stage adaptive learning procedure. The original form of the model caters for multiple objectives by including each goal in the objective function and then assigning arbitrary weights to each goal in order to stimulate potential tradeoffs. However, the specification of such welfare function a priori presupposes complete information about all possible actions and the tradeoffs between these actions. Since this information is rarely available, interactive decision methods are more appropriate. For this reason, the DREAM model will be restructured as a multistage version of the Harmonious Adaptive Learning Procedure (HALP), to allow the various decision makers to become more actively involved with the multilevel process of compromise.

The broad structure of the model is essentially a set of relationships between (a) the population and resources availability in different regions, (b) the economic activities in different enterprises, projects and regions, and (c) the flows of goods and services on a transport network with certain distance-cost characteristics. These relationships are expressed in mathematical form using a set of linear constraint equations.

## SUMMARY

In order to obtain solutions of multi-objective, multi-level, and multi-stage problems, it is necessary to develop a composite methodology which is flexible enough to encompass the complete typology of multi-objective programming and multi-criteria evaluation models. The composite methodology which is suitable, is an interactive type and referred to as Harmonious Adaptive Learning Procedure (HALP). The adaptive learning procedure implies the notion of satisficing rather than optimizing.

To solve the problems of regional diversity, multiple-objective, multi-stage, and multi-level decision making, a Dynamic Regional Economic Allocation Model (DREAM) can be developed. By developing this model, the full set of interdependencies within conflicting subsystems and between conflicting goals can be assessed. Since the DREAM model can be used in this study, it is possible to analyze the multi-objective, multi-level, multi-stage development strategy, in which goal conflicts can either be resolved simultaneously or sequentially overtime. This development planning model also allocates the resource by a stepwise interactive planning scheme of multi-stage decision processes at the cabinet, ministerial, regional, and project levels. The dynamic and simulation results from the proposed study should be useful in indicating the direction and magnitude of investment in the fisheries sector. Therefore, these results should be useful to policy makers who must make choices among conflicting goals in fisheries development.

## REFERENCES

- Bailey, C. 1988. The Political Economy of Marine Fisheries Development in Indonesia. Cornell South East Asia Program No: 46 (October).
- Batten, D.F. 1984. Adaptive Learning and Multistage Compromises for Multilevel Decision Making in Macroeconomic Systems. In: M. Despontin et al (eds.): Macroeconomic Planning with Conflicting Goals. Berlin. Springer-Verlag.
- DGF. 1990. REPELITA V Sub Sektor Perikanan. Jakarta. Direktorat Jenderal Perikanan, Departemen Pertanian.
- Nijkamp, P. and P. Rietveld. 1981. Multi-objective Multi-level Policy Models: An Application to Regional and Environment Planning. European Economic Review 15: 63-89.

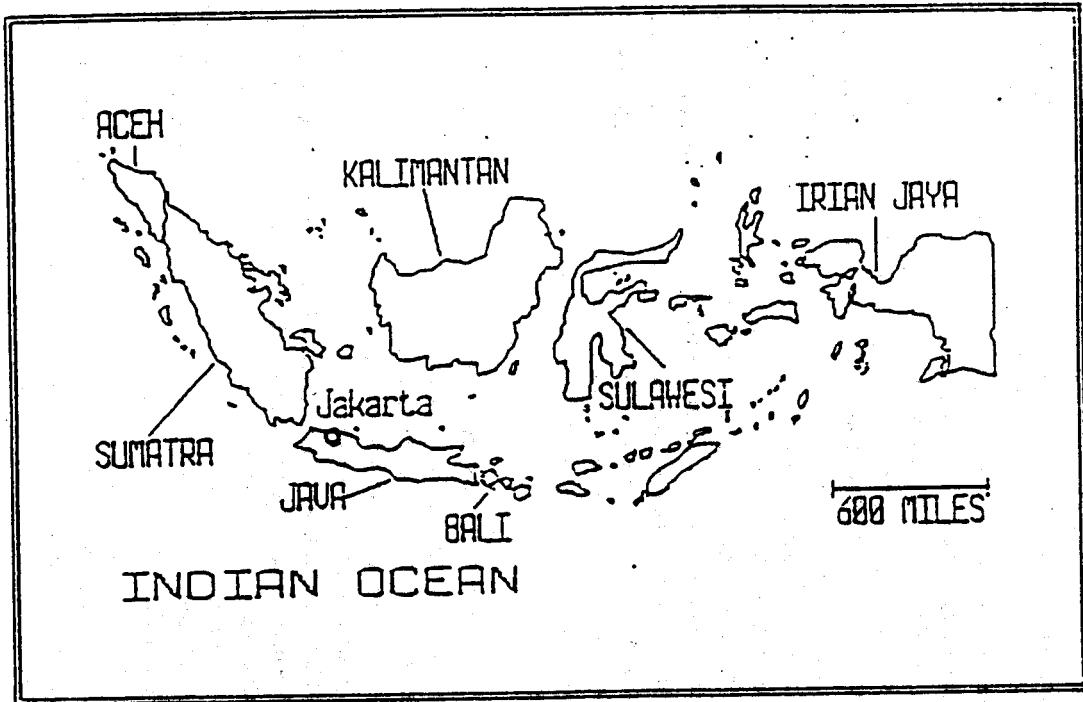

Appendix 1. Map of Indonesia.

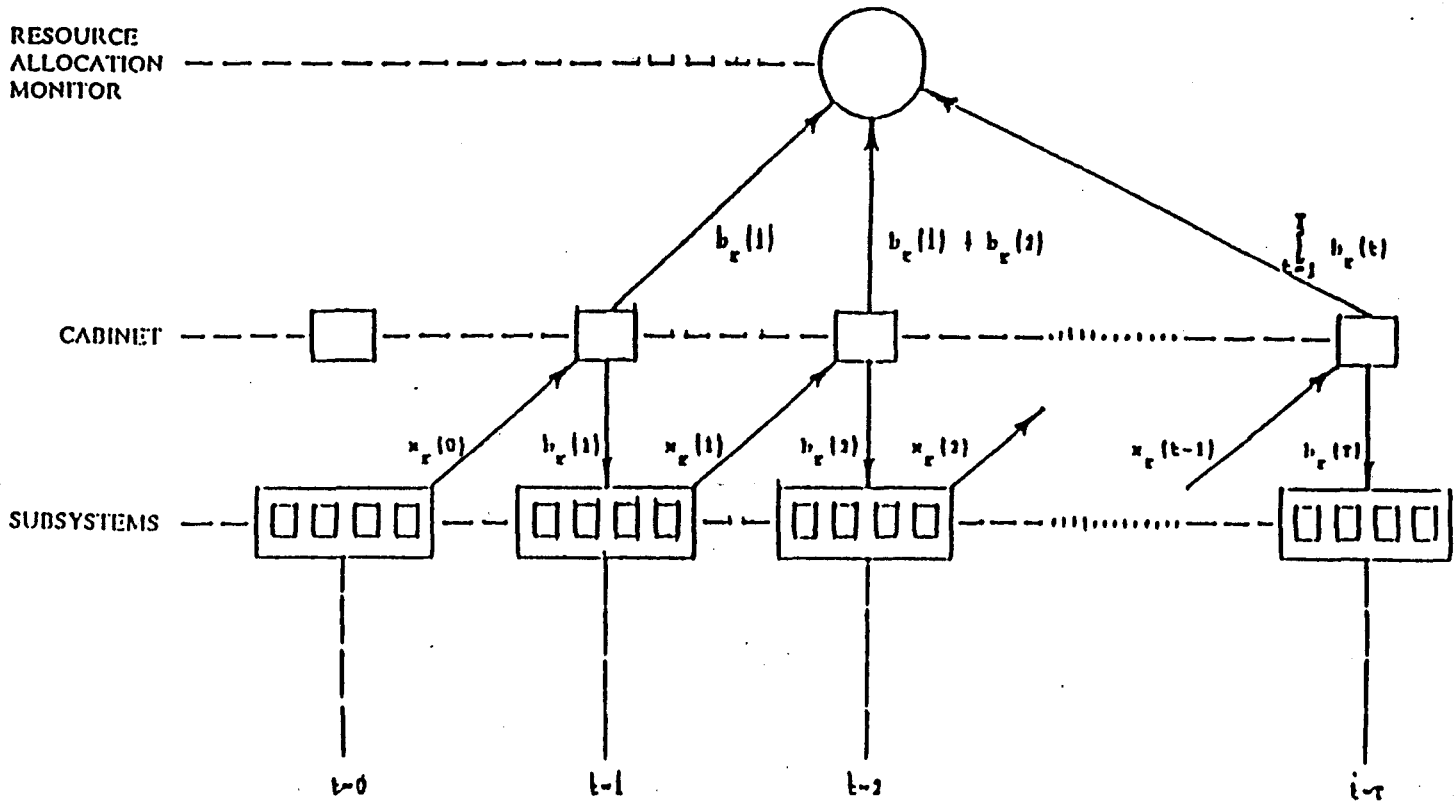

Appendix 2. Compromise solutions in multistage decision making (adapted from Batten, 1984).